

# A/C MOUNTING BRACKETS

## AIR CONDITIONER BRACKET

**Note:** *Anchor Bolts Not Supplied*

**SIZE RANGE:** 16" x 30" and 16" x 36" (supplied with gusset)

**MATERIAL:** Carbon Steel

**FINISH:** Polyester Coated

**SERVICE:** To support the installation of air conditioners.

**ORDERING:** Specify size, figure number, and name.

Figure  
**AC 100**  
**AC 200**

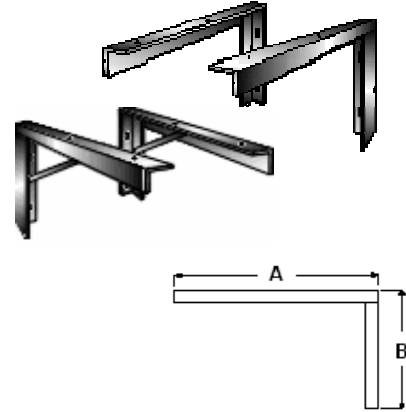

SIZE	SPECIFICATION DATA			APP'X WT. PER SET (LBS)
	MATERIAL	A	B	
<b>AC100</b>	3/16" x 1 3/4" ANGLE IRON	30"	16"	16#
<b>AC200</b>	3/16" x 1 3/4" ANGLE IRON	36"	16"	22#